

Original Research Article

Discussion on the Teaching of Student-Centered Circuit Analysis Course

Yangyang Yu, Wenjing Liu

Guizhou Minzu University, Guiyang 550025, China

Abstract: In view of the problems existing in the teaching of Circuit Analysis in our school, this paper puts forward that the teaching mode based on “teaching” should be changed to “learning”, with teachers as the guide and students as the main body, and students’ autonomous learning ability should be highlighted, so as to improve the teaching quality. This paper through the analysis of circuit analysis course and the characteristics of circuit analysis teaching in our school, takes the principle of improving students’ practical ability and enhancing students’ initiative, constantly promote the teaching reform and improve the teaching effect from the teaching content and teaching method two aspects.

Keywords: Circuit Analysis; Autonomous Learning; Teaching Content; Teaching method

1. Introduction

As the main technical basic course of electronic information and electricity, each engineering major has carried out this course in different depth and level, and as the first basic course of students’ contact after entering school, the purpose of this course is to make students have preliminary electronic engineering consciousness, to cultivate students’ computational thinking ability and analytical design ability of practical engineering circuit, and to pay attention to the combination of theory with practice. And to make students have the ability of simple practice, prepare the necessary theoretical knowledge for the follow-up related circuit courses, and lay a certain foundation for the design and development of circuits.

2. Current teaching situation and main problems of circuit analysis course

The circuit analysis course not only has the logical characteristics of many theoretical contents, complicated knowledge points and more mathematical derivation, but also has to consider the factors of practical engineering application. It is the bridge between the basic course and the professional course, and also lays the basic position of the circuit analysis course in the subsequent professional curriculum. The degree of mastering the course content will directly affect the learning effect of the professional course. With the continuous deepening of the reform of teaching content and teaching method, the teaching time of this course is gradually reduced. How to improve the teaching quality under the premise of ensuring the teaching content is not compressed is an urgent need for in-depth discussion and research. The traditional circuit analysis course is mainly based on teachers’ explanation and theoretical teaching, and because of the more contents and less class hours, the number of experimental teaching hours and the number of interactive hours with students in the classroom are very few. Too much emphasis on the depth and breadth of theoretical knowledge, resulting in students do not fully understand the physical meaning of the circuit behind the formula, followed by the memory of the formula, so students’ study of theoretical knowledge only stays on the surface. In addition, the practice link can not follow up in time to help students better understand the theoretical knowledge, the after-class homework appeared speculative and skillful, plagiarism phenomenon is obvious, can not achieve the teaching objectives of the curriculum, and failed to provide better theoretical guidance for the practice link, which directly leads to the decrease of students’ enthusiasm and autonomy in learning.

The course of circuit analysis has strong practicality. Many students are still unable to use the methods they have learned flexibly to analyze circuits in the face of practical circuits after learning the course. The reason is that the traditional teaching method is highly theoretical. Due to a large number of concepts and mathematical derivation, the classroom atmosphere is dull and boring. Coupled with the teachers’ cramming teaching method, students obey teachers and books unconditionally, so their learning initiative and independence has gradually disappeared. In the traditional experimental teaching, the experimental equipment provided by the laboratory is mainly verification experiment, and there are few comprehensive innovative experiments. The objects, methods and steps of the experiment are worked out by the teacher in advance. The experimental process is usually for the teacher to explain the principle and content of the experiment first, and then according to the experimental handout, the

Copyright © 2020 Yangyang Yu *et al.*

doi: 10.18282/l-e.v9i2.1388

This is an open-access article distributed under the terms of the Creative Commons Attribution Non-Commercial License

(<http://creativecommons.org/licenses/by-nc/4.0/>), which permits unrestricted non-commercial use, distribution, and reproduction in any medium, provided the original work is properly cited.

students carry on the wiring experiment and observe and record the waveform in the oscilloscope according to the steps. Finally, the instructor checks whether the experimental results are correct. Students do not have their own innovative ideas in the process of the experiment, the completion of the experimental project mainly depends on the experimental box, coupled with the limitations of school hours, the experiment is not repetitive, so students can not carry out repetitive error correction and verification after leaving the laboratory, resulting in the experimental curriculum does not play a full role.

3. Concrete measures and methods of teaching reform

In view of the current teaching situation and main problems of circuit analysis courses mentioned above, it is urgent to establish a new teacher-student relationship with teacher-led, student-oriented teaching, equal and harmonious teacher-student relationship, and advocate interactive, heuristic and discussion teaching methods. On the basis of the original basic principles, basic methods and basic skills that need to be examined in the teaching content, we should attach importance to the students' ability to analyze and solve problems, at the same time emphasize the practical ability, and fully arouse the enthusiasm, initiative and creativity of students in learning.

In view of the problems existing in students' learning process and the objectives of teaching reform, specific measures and methods of reform are formulated as follows:

(1) Ensure the orderly arrangement of the teaching content of each class, determine the appropriate teaching programs and plans, including teaching objectives, teaching difficulties, teaching methods and the timing of each knowledge point, and so on. In this way, students can clearly understand the knowledge points of each class, that is, "learn what"; To master what level, so as to determine the learning objectives, to achieve the specific learning objectives students should adopt what kind of learning strategies, namely "how to learn"; Finally, teachers need to make comprehensive and comprehensive evaluation of teaching effect through classroom questioning or other means to ensure that students can achieve the target effect.

(2) Combining multimedia teaching with traditional teaching, using MOOC and classroom teaching to carry out mixed practical teaching. Figure 1 below shows the extracurricular and in-class teaching design. Before class, teachers design pre-class tasks to guide students' autonomous learning, and publish relevant video materials on MOOC platform. In class, they answer the problems encountered by students in pre-class learning by asking questions and summing up, help students build knowledge system, and sort out the relationship between various knowledge points. Through the way of in-class test to test the students' pre-class learning and mastery, and give timely feedback. The study of basic knowledge is mainly outside the classroom, and the feedback of questions, the absorption and consolidation of knowledge are mainly carried out in the classroom, and the interaction between teachers and students is realized through the links of asking questions, answering questions, testing, discussing and so on, so as to promote the diversity of classroom learning and solve the shortcomings of the boring theoretical courses that students think.

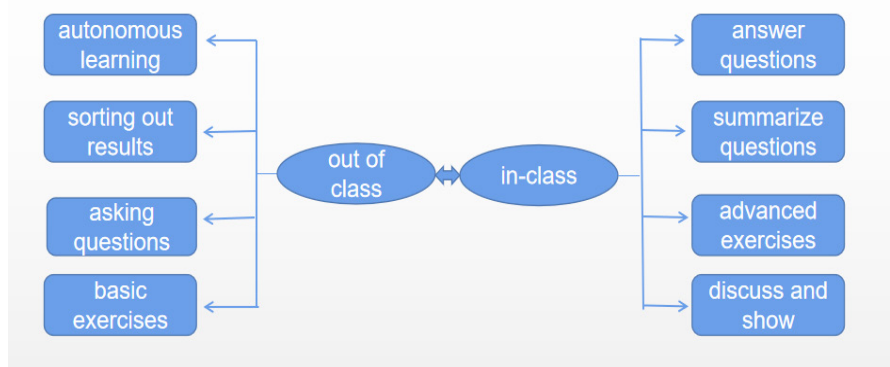

Figure 1. Extracurricular and in-class teaching content design.

(3) Adding the circuit explanation of virtual simulation to the theoretical course can make the boring analysis circuit course vivid and increase the students' interest in learning at the same time. Pay attention to the combination of theoretical learning and case analysis, from the basic knowledge, basic principles to practical application has a process of gradually deepening understanding and transformation and adaptation, targeted selection of engineering examples to carry out teaching, based on the engineering model to elaborate the basic principles, abstract theoretical knowledge and objective engineering examples to establish a relationship, so that students in-depth understanding of theoretical knowledge at the same time Imperceptibly improve the ability to use knowledge.

For example, when explaining the knowledge of superposition theorem, you can design and use the simulation software Multisim to assist in teaching, as shown in Figure 2. First, the ammeter is connected to the circuit alone, and the other two voltage sources are short-circuited through the switch to record the voltage value of both ends of the 40 Ω resistor, and then the two voltage sources are separately connected to the circuit, and the current source is cut off through the switch to record the voltage value of both ends of the 40 Ω resistance at this time. Finally, the three voltage values are added together to verify whether the final result is equal to the voltage value of both ends of the 40 Ω resistance in the three electricity meters at the same time. Through the combination of practical calculation and software simulation, students can see the changes of voltage and current in the circuit more clearly, and the boring theoretical knowledge becomes lively. It not only gets twice the result with half the effort in teaching, but also helps to improve students' interest in learning and the ability to analyze and solve problems, so as to greatly improve the teaching quality and teaching efficiency.

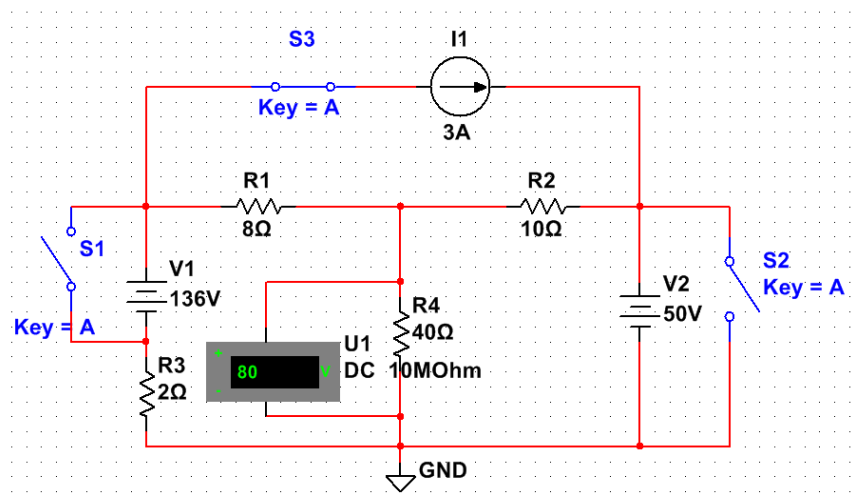

Figure 2. Superposition theorem simulation circuit.

(4) Focus on the combination of theory and practice. Circuit experiment is an important link in the course of circuit analysis. As the first course to enter the laboratory contact, students should be able to master the basic skills of the experiment and the knowledge of safe operation, understand and skillfully use electrical and electronic instruments, as well as the measurement of circuit component parameters and the identification of components. Improving students' practical ability is an important way to train students to observe and solve practical problems. Due to the limitation of experimental hours, most of the time can only be done to verify the experiment, can not give full play to and improve the innovative ability of students, so the experimental teaching content is divided into "theoretical experiment" and "design experiment", in which the "theoretical experiment" is based on the principle and verification experiment, mainly consolidating the students' understanding and application of the basic theory. The "design experiment" is based on the comprehensive and design experiment, which is given by the teacher. The students complete the experiment under the guidance of the teacher according to their own interest, improve the ability of comprehensive application of knowledge, train the students to master the ability of circuit analysis, the ability of reading circuit diagram and the ability of troubleshooting circuit.

4. Conclusion

The teaching reform of this circuit analysis changes the teaching mode based on "teaching" to "learning", takes the teacher as the guide, takes the student as the main body, and emphasizes the students' autonomous learning ability, so as to improve the teaching quality. Through the analysis of the characteristics of circuit analysis course and university teaching, in order to improve students' practical ability and enhance students' initiative, in the teaching reform of circuit analysis course, this paper puts forward the combination of theoretical knowledge learning and engineering example analysis in teaching content, the combination of knowledge explanation and simulation software assistance in teaching method, and the combination of circuit experiment and simulation software simulation experiment in teaching practice. Continue to promote teaching reform and improve teaching effectiveness.

References

1. Zeng Songwei, Zhou Suyin, Zhang Yun, etc. Discussion on Teaching Reform of Circuit Analysis [J]. Journal of Electrical and Electronic Teaching, 2014, 36(006): 53-55.
2. Qujian. Improvement and discussion on the classroom teaching mode of circuit analysis [J]. Higher Education Research: Chengdu, 2008 (03): 41-42.